

Operating Instructions

Introduction

For safe and correct use, be sure to read Safety Information before using the machine.

How to Read the Manuals

Symbols

This manual uses the following symbols:



Indicates points to pay attention to when using the functions, be sure to read these explanations.



Indicates supplementary explanations of the machine's functions, and instructions on resolving user errors.

[]

Indicates the names of keys on the machine's display or control panels.

Disclaimer

Contents of this manual are subject to change without prior notice.

To the maximum extent permitted by applicable laws, in no event will the manufacturer be liable for any damages whatsoever arising out of failures of this machine, losses of the registered data, or the use or non-use of this product and operation manuals provided with it.

In no event will the manufacturer be responsible for any documents created by you using this machine or any results from the data executed by you.

Notes

The manufacturer shall not be responsible for any damage or expense that might result from the use of parts other than genuine parts from the manufacturer with your office products.

Some illustrations in this manual might be slightly different from the machine.

Model-Specific Information

This section explains how you can identify the region your machine belongs to. There is a label on the rear of the machine, located in the position shown below. The label contains details that identify the region your machine belongs to. Read the label.

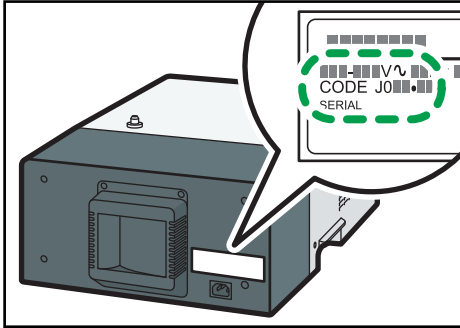

DSB062

The following information is region-specific. Read the information under the symbol that corresponds to the region of your machine.

 **Region A** (mainly Europe, Asia, and China)

If the label contains the following, your machine is a region A model:

- 220-240 V

 **Region B** (mainly North America)

If the label contains the following, your machine is a region B model:

- 120-127 V

 **Note**

- Dimensions in this manual are given in two units of measure: metric and inch. If your machine is a Region A model, refer to the metric units. If your machine is a Region B model, refer to the inch units.

Precautions when using the machine

- When installing the machine, provide a gap of at least 5 cm (about 1.9 inches) between each of the left and right sides and the rear and other objects.
- Do not put anything on top of the machine (except for the printer Ri 100).
- If the temperature inside the machine rises, a malfunction will result. Do not block the vents (left, right, and back sides of the machine) by placing or leaning objects against them.

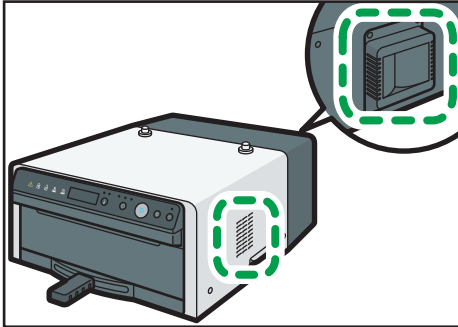

DSA132

- Do not surround the finisher with inflammables with the ignition point of 200 °C (392 °F) or lower.
- This machine has a heater auto-off function. If you do not open the front cover or operate the mode switching lever for 15 minutes after the set temperature is reached by the heating operation, the heater power is automatically turned off.
- Use this machine indoors.
- Use this machine in a place where sufficient ventilation is available.
- When using multiple units, do not stack them.
- Remove the protective cover before inserting the tray into the finisher.

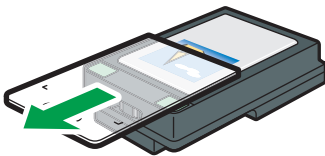

DSA065

- Before heat processing starts, do not touch with your hands the surface where ink is applied.
- When you leave from the finisher for an hour or longer after using it or when you do not use it, make sure to turn the power switch (red) off and unplug the cord.
- As the A4 standard tray and A5 tray becomes hot when continuously used on the finisher, give an interval of five minutes or longer to set them after they are pulled out.
- Take out the tray from the finisher soon after pressing (smoothing wrinkles/flattening fibers) or fixing ink is completed. Leaving the tray in the hot finisher for a long time may cause the tray to malfunction.

Preparation Before Using the Finisher

Take the power cord out before using the finisher.

- 1** Put a piece of cardboard or a card between the front cover and the control panel, and then slide it from right to left. When the front cover lock is released, pull the front cover forward.

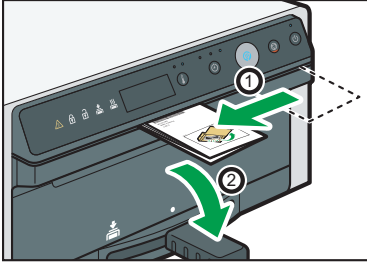

DSB085

- 2** Take the box out from the inside of the finisher.

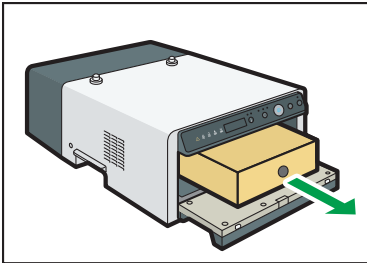

DXH002

- 3** Open the box and take the power cord out.

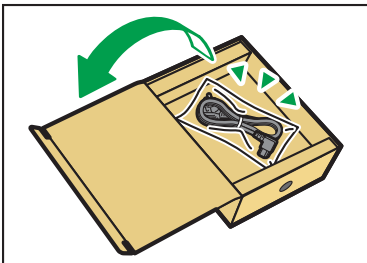

DXH003

Precautions for Washing

- Note the following handling precautions for T-shirts and sweatshirts:
 - Turn garments inside out before washing them.
 - When washing T-shirts and other garments by hand, dissolve some neutral detergent in lukewarm water of about 30°C (86°F) and wash them without rubbing the printed areas. After that, spin them dry for about 1 minute in a washing machine, smooth wrinkles, and then hang them to dry.



DSAS41

- Do not rub the printed surfaces. Doing so may cause discoloration due to friction.



DSAS42

- When washing T-shirts and other garments in a washing machine, turn them inside out so the printed side is inside and put them in a laundry net. After washing them, shake out as much water as possible, smooth out wrinkles, and hang them in the shade to dry.

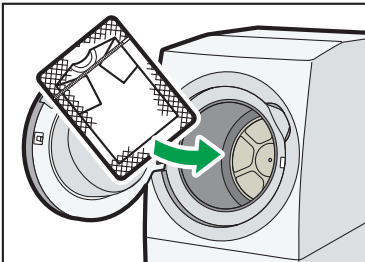

DSAS43

- Do not use a dryer or bleach.
- Avoid ironing the printed surfaces.
- Do not dry-clean garments.

- Note the following handling precautions for tote bags:
 - Do not machine wash tote bags. Doing so may cause the tote bag to lose its shape or cause its colors to fade.
 - When washing tote bags by hand, dissolve some neutral detergent in lukewarm water of about 30°C (86°F) and wash them without rubbing their printed areas. After washing a tote bag, shake it out to remove as much water as possible. Then, flatten it to remove wrinkles and dry it in the shade.

Laws and Regulations

User Information on Electrical & Electronic Equipment

Users in the countries where this symbol shown in this section has been specified in national law on collection and treatment of E-waste

Our Products contain high quality components and are designed to facilitate recycling.

Our products or product packaging are marked with the symbol below.



The symbol indicates that the product must not be treated as municipal waste. It must be disposed of separately via the appropriate return and collection systems available. By following these instructions you ensure that this product is treated correctly and help to reduce potential impacts on the environment and human health, which could otherwise result from inappropriate handling. Recycling of products helps to conserve natural resources and protect the environment.

For more detailed information on collection and recycling systems for this product, please contact the shop where you purchased it, your local dealer or sales/service representatives.

All Other Users

If you wish to discard this product, please contact your local authorities, the shop where you bought this product, your local dealer or sales/service representatives.

For Users in India

This product including components, consumables, parts and spares complies with the "India E-waste Rule" and prohibits use of lead, mercury, hexavalent chromium, polybrominated biphenyls or polybrominated diphenyl ethers in concentrations exceeding 0.1 weight % and 0.01 weight % for cadmium, except for the exemptions set in the Rule.

For Turkey only

AEEE Yönetmeliğine Uygundur.

Bu sistem sarf malzemeleri ve yedek parçaları da dahil olmak üzere AEEE Yönetmeliğine Uygundur.

Note for the Battery and/or Accumulator Symbol (For EU countries only)



In accordance with the Battery Directive 2006/66/EC Article 20 Information for end-users Annex II, the above symbol is printed on batteries and accumulators.

This symbol means that in the European Union, used batteries and accumulators should be disposed of separately from your household waste.

In the EU, there are separate collection systems for not only used electrical and electronic products but also batteries and accumulators.

Please dispose of them correctly at your local community waste collection/recycling centre.

Notes to Users in the United States of America

FCC Rules

NOTE:

This equipment has been tested and found to comply with the limits for a Class B digital device, pursuant to Part 15 of the FCC Rules. These limits are designed to provide reasonable protection against harmful interference in a residential installation. This equipment generates, uses and can radiate radio frequency energy and, if not installed and used in accordance with the instructions, may cause harmful interference to radio communications. However, there is no guarantee that interference will not occur in a particular installation. If this equipment does cause harmful interference to radio or television reception, which can be determined by turning the equipment off and on, the user is encouraged to try to correct the interference by one or more of the following measures:

- Reorient or relocate the receiving antenna.
- Increase the separation between the equipment and receiver .

- Connect the equipment into an outlet on a circuit different from that to which the receiver is connected.
- Consult the dealer or an experienced radio/TV technician for help.

Caution:

Changes or modifications not expressly approved by the party responsible for compliance could void the user's authority to operate the equipment.

Notes to users in the state of California  **Region B**

Perchlorate Material - special handling may apply. See: www.dtsc.ca.gov/hazardouswaste/perchlorate

Guide to Components

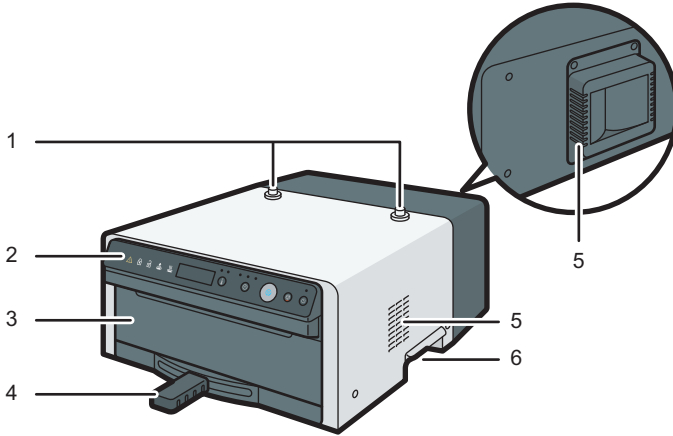

DSA134

1. Brace to prevent falling
2. Control Panel
3. Front Cover
4. Mode Switching Lever
5. Vents (on the left, right, and back sides of the machine)
6. Handles for Transporting and Moving (on the left and right sides of the machine)

Names of Control Panel

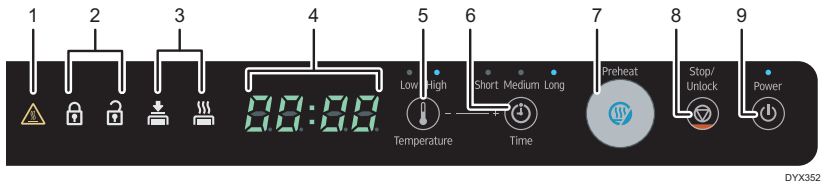

1. High temperature caution indicator

Lights up when the machine is hot.

2. Unlock indicator

The front cover will not open when locked.

3. Mode indicator

Lights up during pressing (smoothing wrinkles/flattening fibers) or fixing (fixing ink).

4. Time/temperature indicator

Displays the set temperature and the time remaining until processing is completed.

5. [Temperature] key

See "Smoothing Wrinkles/Flattening Fibers" or "Fixing Ink".

6. [Time] key

See "Smoothing Wrinkles/Flattening Fibers" or "Fixing Ink".

7. [Preheat] key

When the [Preheat] key is lit, press the [Preheat] key to start preheating.

When the [Preheat] key is unlit, preheating is completed.

When the [Preheat] key is flashing, preheating is under way.

8. [Stop/Unlock] key

When this key is pressed while preheating is under way, preheating stops.

In standard mode, press the [Stop/Unlock] key for at least 1 second to unlock the front cover.

9. [Power] key

Turns the power on and off.

To turn off the power, press and hold the [Power] key for 1 second or more.

When Attaching the Finisher to the Printer

- 1** Attach the finisher to the printer so that the support on the finisher and the hole on the bottom of the printer align.

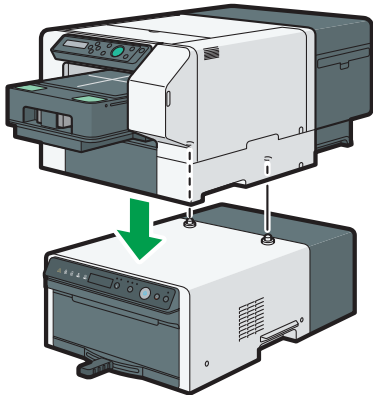

DYX303

- 2** Make sure that the support and the hole on the back of the printer match.

Turning On the Power

1 Plug the power cord fully into the machine.

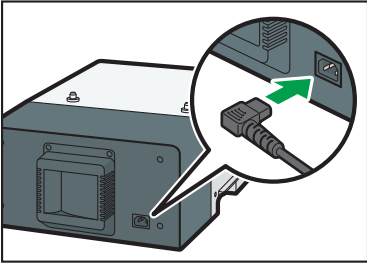

DSA135

2 Plug the power cord fully into the wall outlet.

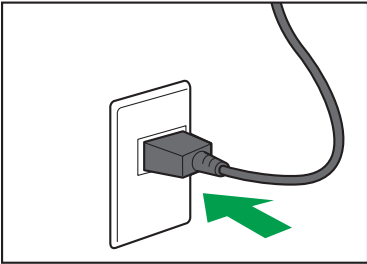

DSA518

3 Press the [Power] key.

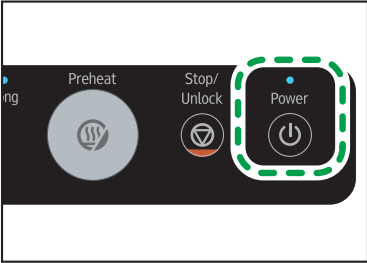

DSB512

Note

- To turn off the machine's power, press the [Power] key for 1 second or more.

Operating Mode of the Finisher

⚠ CAUTION:

- A parent or guardian must be present if infants, children, or people who need assistance use the machine, and they should be very careful when using it. Otherwise, injury or burns may result.

The finisher has "Standard mode", "Professional mode", and "Professional 2 mode".

To switch between these modes, press the [Temperature] key and the [Time] key simultaneously for 2 seconds or more.

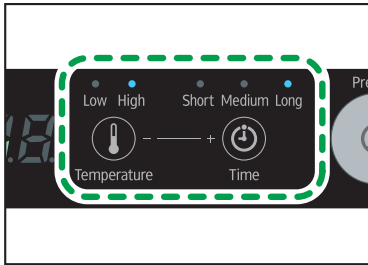

The operating mode changes as follows.

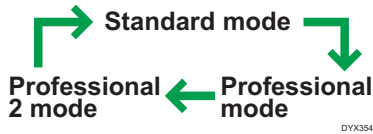

■ Standard mode

The factory-default setting is standard mode. The finisher has the following functions to prevent children from touching the inside of the finisher accidentally when it is very hot.

- When the inside of the finisher exceeds 70 °C (158 °F), the front cover locks. To open the front cover, press the [Stop/ Unlock] key for at least 1 second.

The surface of the heater and the fabric are not in contact with each other during fixing processing, so the surface of the heater will not become dirty.



■ Professional mode

To use this mode, switch from standard mode.

As this mode is for users who are accustomed to using the finisher, the front cover does not lock even when the temperature of the inside of the finisher exceeds 70 °C (158 °F).

However, during press processing and fixing processing, the front cover locks regardless of whatever mode is used to prevent erroneous operations.

The surface of the heater and the fabric are not in contact with each other during fixing processing, so the surface of the heater will not become dirty.



■ Professional 2 mode

To use this mode, switch from professional mode.

As this mode is for users who are accustomed to using the finisher, the front cover does not lock even when the temperature of the inside of the finisher exceeds 70 °C (158 °F).

However, during press processing and fixing processing, the front cover locks regardless of whatever mode is used to prevent erroneous operations.

The surface of the heater and the fabric are in contact with each other during fixing processing, so the regular cleaning of the surface of the heater is necessary.



Set Temperature and Time

The temperature and time are set at the factory.

	Temperature		👤 Press time			🔥 Fix time		
	Low	High	Short	Medium	Long	Short	Medium	Long
Standard	150 °C (302°F)	170 °C (338°F)	30sec fixed			1min	3min	6min
Professional	150 °C (302°F)	170 °C (338°F)	30sec fixed			1min	3min	6min
Professional 2	150 °C (302°F)	180°C (356°F)	30sec	3min	4min	30sec		

However, you can change the settings according to how you use the finisher.

To set the temperature and time, press the [Temperature] key or the [Time] key.

- You can select either "Low" or "High" for the temperature.
- You can select "Short", "Medium", or "Long" for the time.

It is set to a fixed number for each.

⬇️ Note

- You can set any number. Press the [Temperature] key or the [Time] key for 2 seconds or more, and use the [Temperature] key or the [Time] key to set the temperature and time. To confirm the settings, press the [Preheat] key. To cancel the settings, press the [Stop/Unlock] key.
- You can set the temperature in units of 5°C (41°F) between 140°C (284°F) and 180°C (356°F).
- You can set the time in units of 30 seconds between 30 seconds and 6 minutes.



- To change the press time in the professional 2 mode, press and hold the [Time] key and [Stop/Unlock] key at the same time for 2 seconds, and use the [Temperature] key and the [Time] key to set the temperature and time. To confirm the settings, press the [Preheat] key.

* You cannot set more than 6 minutes for the total time, including that set by "Long" for the press time plus the fixing time.

Smoothing Wrinkles/Flattening Fibers

⚠ CAUTION:

- Do not touch the inside of the finisher when you open the front cover. The surface of the heater will be as high as about 180 °C (356 °F).
- Especially never touch the black heater on the upper part of the inside of the machine.
- When taking a T-shirt out of the tray after a print image has been fixed to it, do not touch the front side or metal plate (black) on the back side of the cassette's table because it is hotter than 100 °C (212 °F).

- A parent or guardian must be present if infants, children, or people who need assistance use the machine, and they should be very careful when using it. Otherwise, injury or burns may result.

★ Important

- Before installing the tray to the finisher, do not spray any liquid on the fabric or tray. If you heat a wet cloth or tray in the finisher, the color of the tray table may stain the back side of the fabric.

↓ Note

- You can unlock the front cover manually if the power is shut off due to a power failure or other causes while the front cover is locked. Insert a piece of cardboard or a card between the front cover and the operation panel and slide it from the right to the left as you pull the front cover towards you.

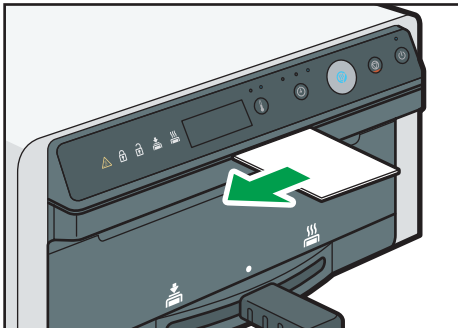

DSA145

Standard mode

- 1 Press the [Power] key to turn on the power.

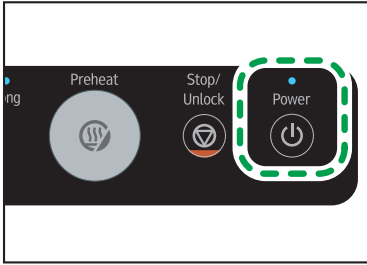

DSB512

- 2 Slide the mode switching lever to the center.

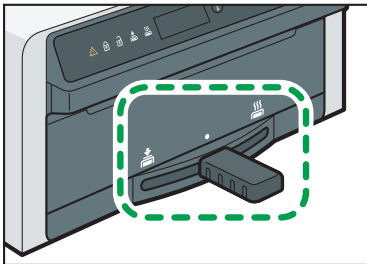

DSA136

- 3 Set the heater temperature with the [Temperature] key.

Set the temperature according to the fabric on which you print. The default setting is "High".

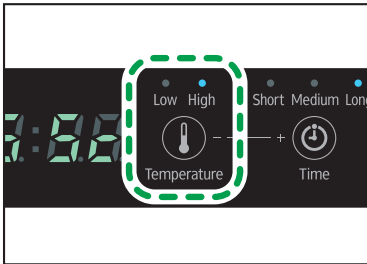

DYX356

- 4 When the [Preheat] key is lit, press the [Preheat] key to start preheating. When the [Preheat] key is unlit, no operation is necessary because preheating is completed.

When preheating is completed, an alarm sounds and the set temperature of the time/temperature indicator flashes.

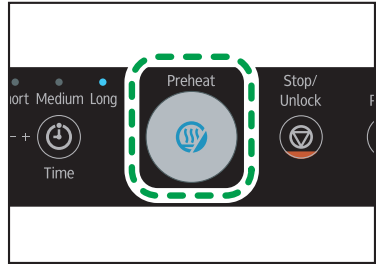

DYX357

- 5 Press the [Stop/Unlock] key for 1 second or more to open the front cover.

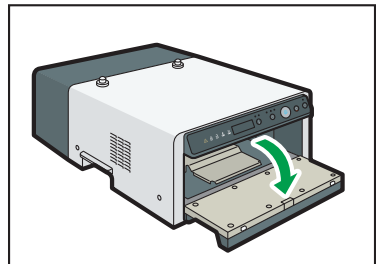

DSA137

- 6 Load the tray.

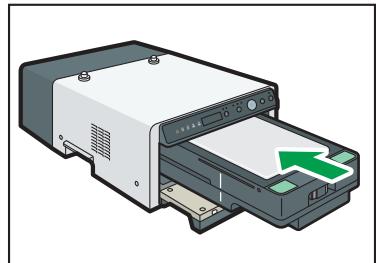

DSA138

- 7** Close the front cover.

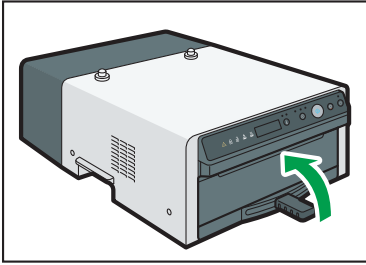

DSA139

- 8** Slide the mode switching lever to the left.

The remaining time is displayed on the time/temperature indicator.

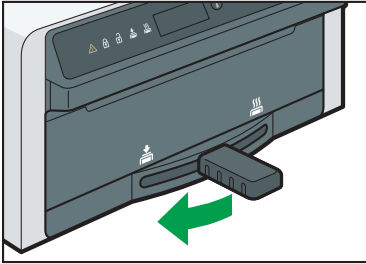

DSA140

- 9** Processing is completed and an alarm sounds.

- 10** Slide the mode switching lever to the center and confirm that the mode indicator turns off.

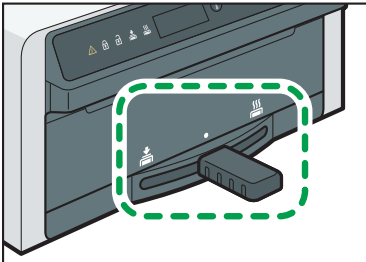

DSA138

- 11** Press the [Stop/Unlock] key for 1 second or more to open the front cover.

Because the inside of the finisher is very hot, do not touch anything inside the finisher.

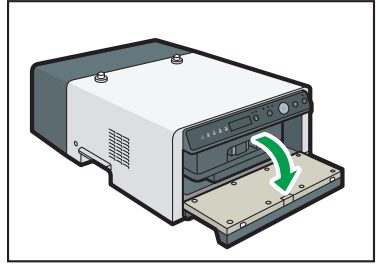

DSA146

- 12** Take out the tray.

Remove the tray, and then close the front cover. If you leave it open more than 10 seconds, an alarm sounds to warn you of risks such as injury or burns.

Professional mode

- 1 Press the [Power] key to turn on the power.

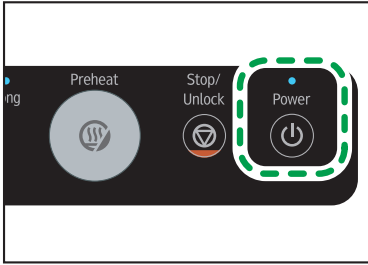

DSB512

- 2 Switch to professional mode. See "Operating Mode of the Finisher".

- 3 Slide the mode switching lever to the center.

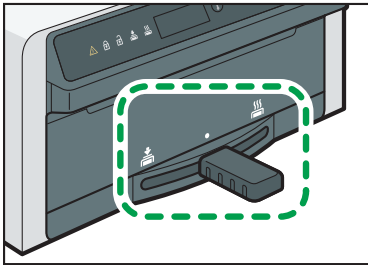

DSA136

- 4 Set the heater temperature with the [Temperature] key.

Set the temperature according to the fabric on which you print. The default setting is "High".

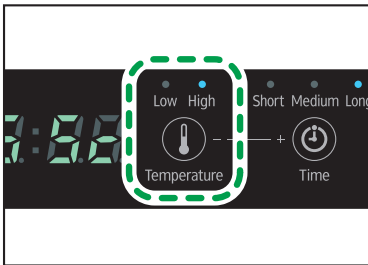

DYX356

- 5 When the [Preheat] key is lit, press the [Preheat] key to start preheating. When the [Preheat] key is unlit, no operation is necessary because preheating is completed.

When preheating is completed, an alarm sounds and the set temperature of the time/temperature indicator flashes.

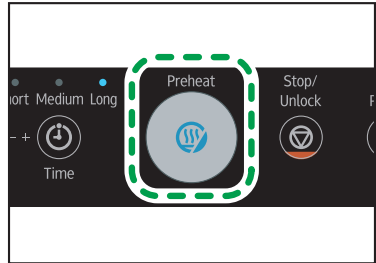

DYX357

- 6 Open the front cover.

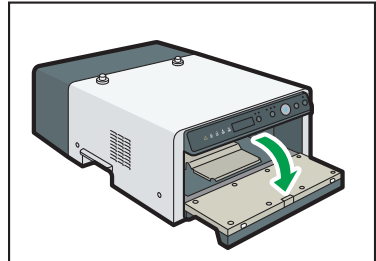

DSA137

- 7 Load the tray.

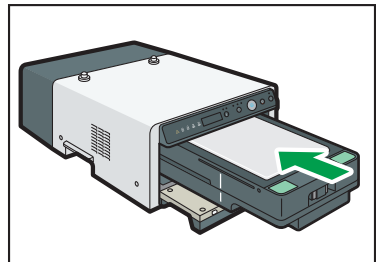

DSA138

- 8** Close the front cover.

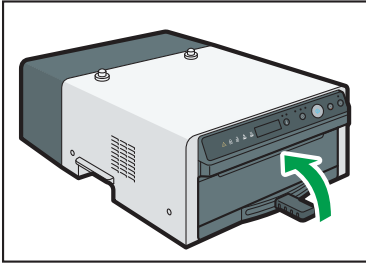

- 9** Slide the mode switching lever to the left.

The remaining time is displayed on the time/temperature indicator.

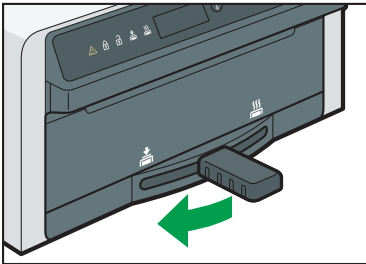

- 10** Processing is completed and an alarm sounds

- 11** Slide the mode switching lever to the center and confirm that the mode indicator turns off.

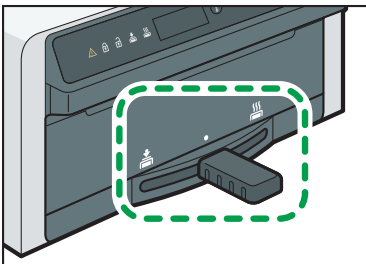

- 12** Open the front cover.

Because the inside of the finisher is very hot, do not touch anything inside the finisher.

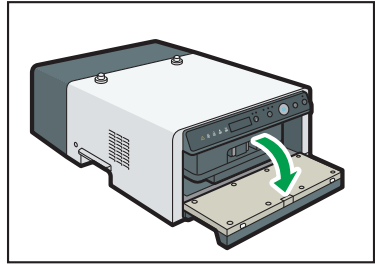

- 13** Take out the tray.

Remove the tray, and then close the front cover. If you leave it open more than 10 seconds, an alarm sounds to warn you of risks such as injury or burns.

Professional 2 mode

- 1 Press the [Power] key to turn on the power.

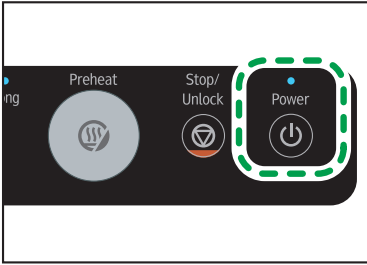

DSB512

- 2 Switch to professional 2 mode. See "Operating Mode of the Finisher".

- 3 Slide the mode switching lever to the center.

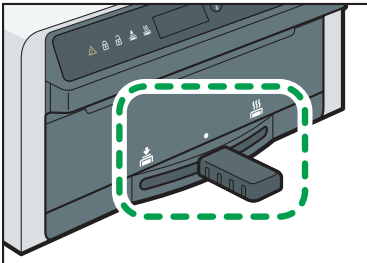

DSA136

- 4 Set the heater temperature with the [Temperature] key.

Set the temperature according to the fabric on which you print. The default setting is "High".

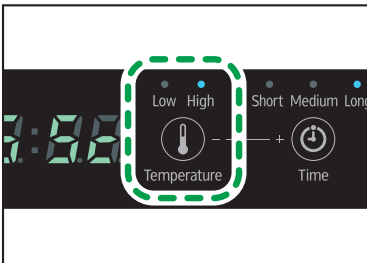

DYX356

- 5 Set the heating time with the [Time] key.

Select "Short" by pressing the [Time] key. The default setting is "Medium".

- 6 When the [Preheat] key is lit, press the [Preheat] key to start preheating. When the [Preheat] key is unlit, no operation is necessary because preheating is completed.

When preheating is completed, an alarm sounds and the set temperature of the time/temperature indicator flashes.

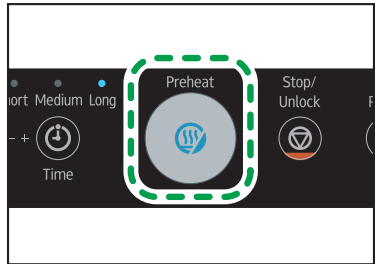

DYX357

- 7 Open the front cover.

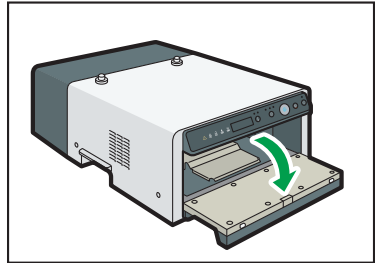

DSA137

- 8 Load the tray.

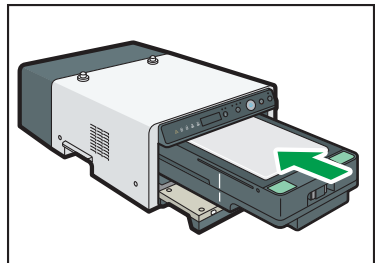

DSA138

- 9** Close the front cover.

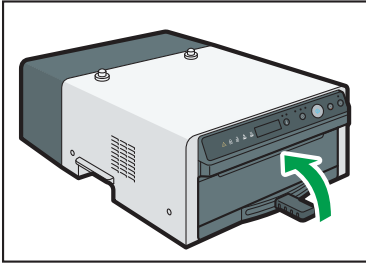

DSA139

- 10** Slide the mode switching lever to the left.

The remaining time is displayed on the time/temperature indicator.

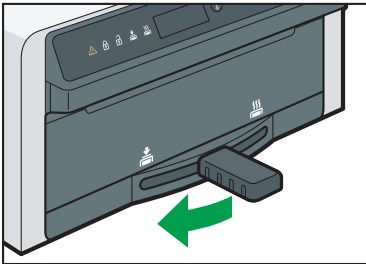

DSA140

- 11** Processing is completed and an alarm sounds

- 12** Slide the mode switching lever to the center and confirm that the mode indicator turns off.

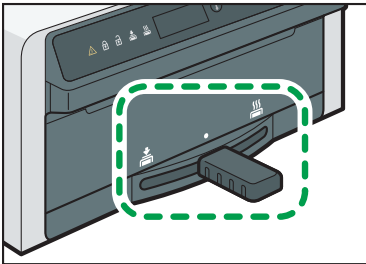

DSA136

- 13** Open the front cover.

Because the inside of the finisher is very hot, do not touch anything inside the finisher.

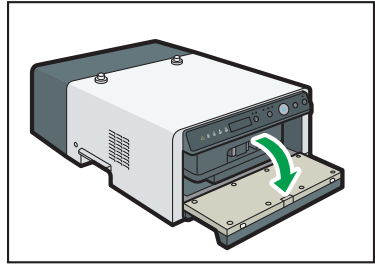

DSA146

- 14** Take out the tray.

Remove the tray, and then close the front cover. If you leave it open more than 10 seconds, an alarm sounds to warn you of risks such as injury or burns.

Fixing Ink

⚠ CAUTION:

- Do not touch the inside of the finisher when you open the front cover. The surface of the heater will be as high as about 180 °C (356 °F).
 - Especially never touch the black heater on the upper part of the inside of the machine.
 - When taking a T-shirt out of the tray after a print image has been fixed to it, do not touch the front side or metal plate (black) on the back side of the cassette's table because it is hotter than 100 °C (212 °F).
-
- A parent or guardian must be present if infants, children, or people who need assistance use the machine, and they should be very careful when using it. Otherwise, injury or burns may result.

★ Important

- Default settings are as follows (Standard mode and Professional mode):
 - Temperature: "High" (170 °C, 338°F)
 - Time: "Medium" (3 minutes)
- Ink might not fix properly or fabric color might change depending on usage conditions. After checking for the garment you use, set the temperature and time.

★ Important

- Before installing the tray to the finisher, do not spray any liquid on the fabric or tray. If you heat a wet cloth or tray in the finisher, the color of the tray table may stain the back side of the fabric.

↓ Note

- You can unlock the front cover manually if the power is shut off due to a power failure or other causes while the front cover is locked. Insert a piece of cardboard or a card between the front cover and the operation panel and slide it from the right to the left as you pull the front cover towards you.

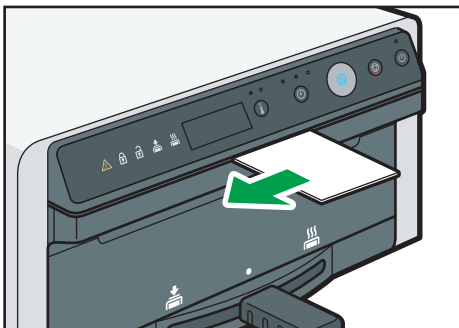

DSA145

Standard Mode

- 1 Slide the mode switching lever to the center.

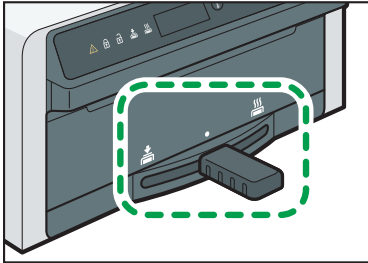

DSA136

- 2 Set the heater temperature with the [Temperature] key.

Set the temperature according to the fabric on which you print. The default setting is "High".

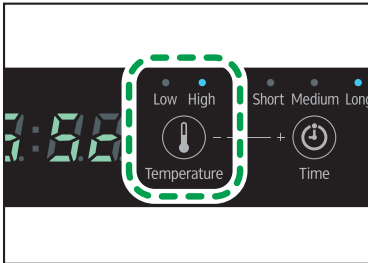

DYX356

- 3 Set the amount of time with the [Time] key.

Set the time according to the fabric on which you print. The default setting is "Medium".

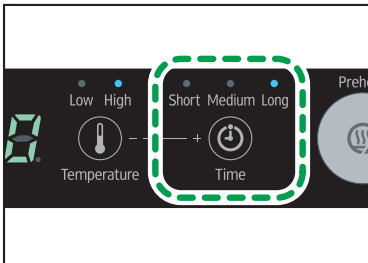

DYX358

- 4 When the [Preheat] key is lit, press the [Preheat] key to start preheating. When the [Preheat] key is unlit, no operation is necessary because preheating is completed.

When preheating is completed, an alarm sounds and the set temperature of the time/temperature indicator flashes.

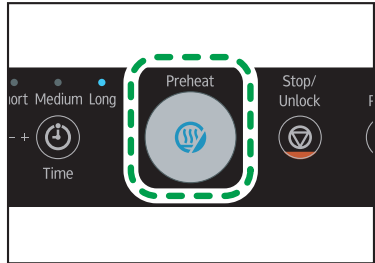

DYX357

- 5 Press the [Stop/Unlock] key for 1 second or more to open the front cover.

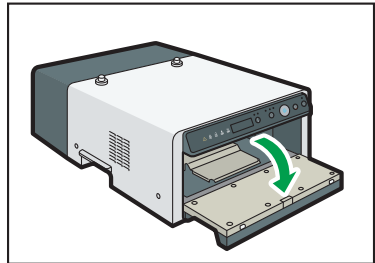

DSA137

- 6 Load the tray.

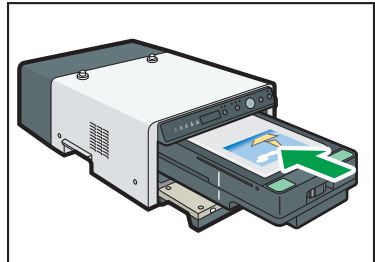

DSA142

- 7** Close the front cover.

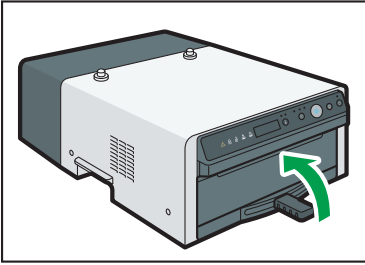

DSA139

- 8** Slide the mode switching lever to the right.

The remaining time is displayed on the time/temperature indicator.

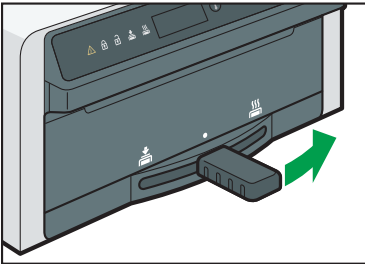

DSA141

- 9** Processing is completed and an alarm sounds.

- 10** Slide the mode switching lever to the center and confirm that the mode indicator turns off.

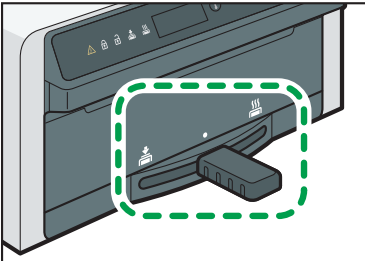

DSA136

- 11** Press the [Stop/Unlock] key for 1 second or more to open the front cover.

Because the inside of the finisher is very hot, do not touch anything inside the finisher.

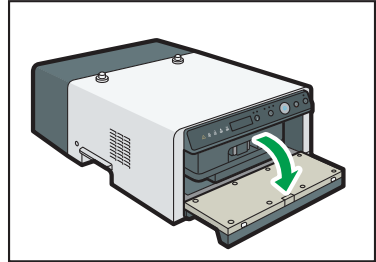

DSA146

- 12** Take out the tray.

Remove the tray, and then close the front cover. If you leave it open more than 10 seconds, an alarm sounds to warn you of risks such as injury or burns.

Professional Mode

1 Switch to professional mode. See "Operating Mode of the Finisher".

2 Slide the mode switching lever to the center.

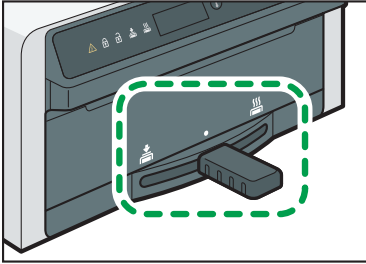

DSA136

3 Set the heater temperature with the [Temperature] key.

Set the temperature according to the fabric on which you print. The default setting is "High".

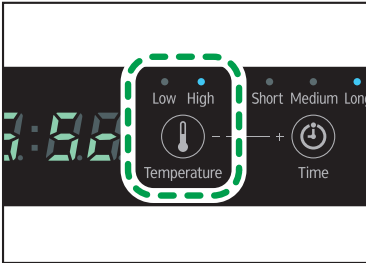

DYX356

4 Set the amount of time with the [Time] key.

Set the time according to the fabric on which you print. The default setting is "Medium".

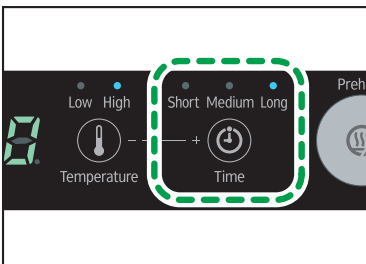

DYX358

5 When the [Preheat] key is lit, press the [Preheat] key to start preheating. When the [Preheat] key is unlit, no operation is necessary because preheating is completed.

When preheating is completed, an alarm sounds and the set temperature of the time/temperature indicator flashes.

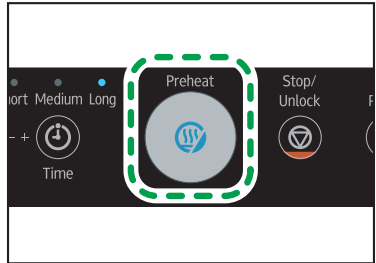

DYX357

6 Open the front cover.

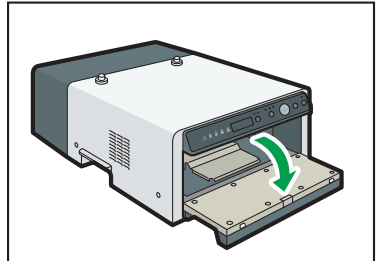

DSA137

7 Load the tray.

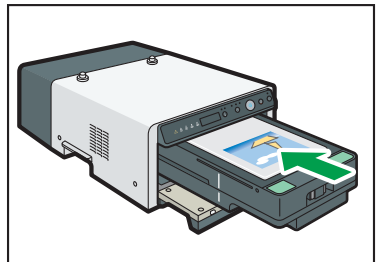

DSA142

- 8** Close the front cover.

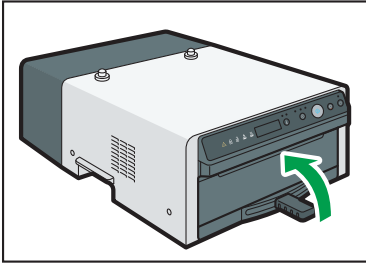

DSA139

- 9** Slide the mode switching lever to the right.

The remaining time is displayed on the time/temperature indicator.

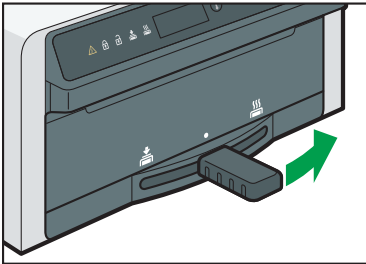

DSA141

- 10** Processing is completed and an alarm sounds.

- 11** Slide the mode switching lever to the center and confirm that the mode indicator turns off.

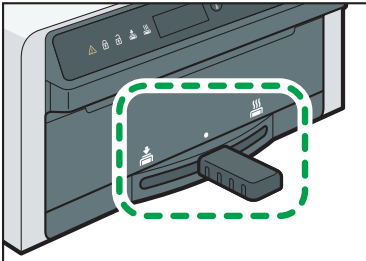

DSA136

- 12** Open the front cover.

Because the inside of the finisher is very hot, do not touch anything inside the finisher.

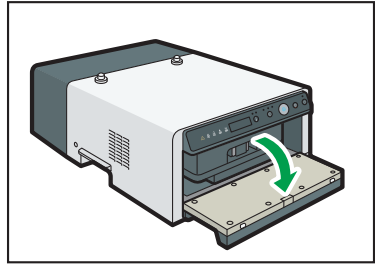

DSA146

- 13** Take out the tray.

Remove the tray, and then close the front cover. If you leave it open more than 10 seconds, an alarm sounds to warn you of risks such as injury or burns.

Professional 2 Mode

1 Switch to professional 2 mode. See "Operating Mode of the Finisher".

2 Slide the mode switching lever to the center.

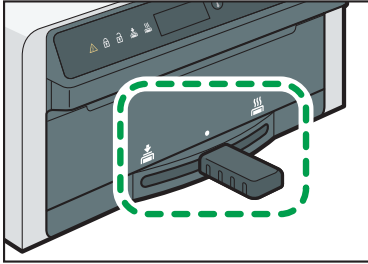

DSA136

3 Set the heater temperature with the [Temperature] key.

Set the temperature according to the fabric on which you print. The default setting is "High".

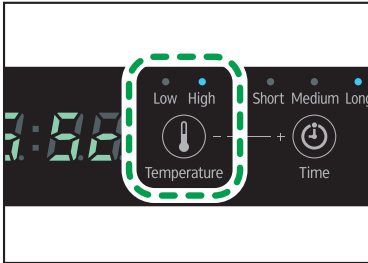

DYX356

4 Set the amount of time with the [Time] key.

Set the time according to the fabric on which you print. The default setting is "Medium".

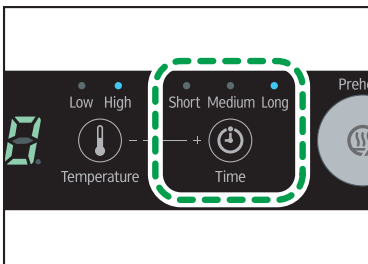

DYX356

5 When the [Preheat] key is lit, press the [Preheat] key to start preheating. When the [Preheat] key is unlit, no operation is necessary because preheating is completed.

When preheating is completed, an alarm sounds and the set temperature of the time/temperature indicator flashes.

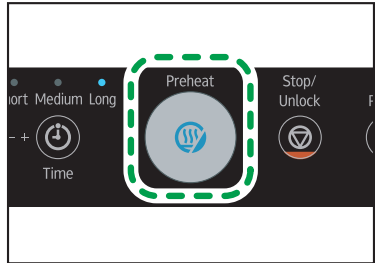

DYX357

6 Open the front cover.

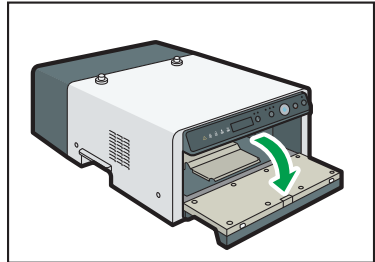

DSA137

7 Load the tray.

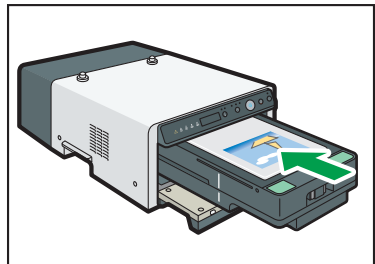

DSA142

- 8** Close the front cover.

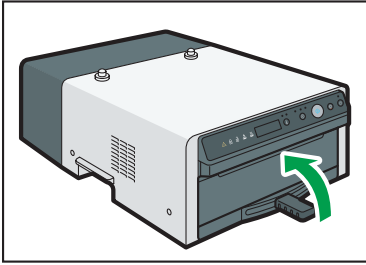

DSA139

- 9** Slide the mode switching lever to the right. Non-contact pre-drying is performed to prevent the ink from adhering to the heater.

The remaining time is displayed on the time/temperature indicator.

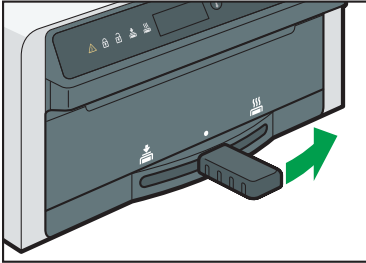

DSA141

- 10** Processing is completed and an alarm sounds.
- 11** Slide the mode switching lever to the center.

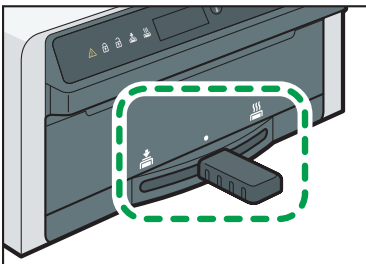

DSA136

- 12** Slide the mode switching lever to the left ().

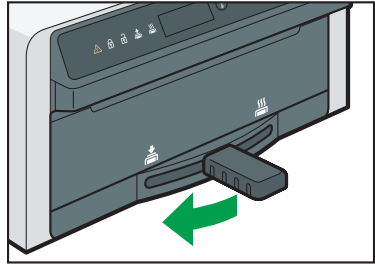

DSA140

The remaining time is displayed on the time/temperature indicator.

- 13** Processing is completed and an alarm sounds.
- 14** Slide the mode switching lever to the center and confirm that the mode indicator turns off.

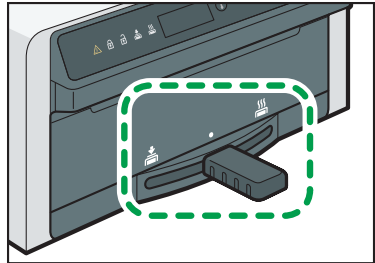

DSA138

- 15** Open the front cover.
- Because the inside of the finisher is very hot, do not touch anything inside the finisher.

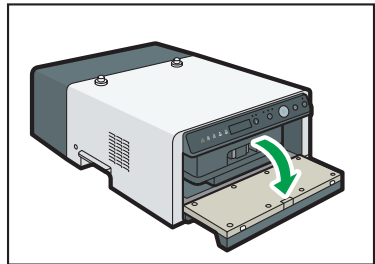

DSA146

- 16** Take out the tray.
- Remove the tray, and then close the front cover. If you leave it open more than 10 seconds, an alarm sounds to warn you of risks such as injury or burns.

Precautions about Professional 2 mode

■ Precautions when cleaning the heater

- Clean the heater regularly (about every 50 prints) with a soft, damp, firmly wrung, cloth.

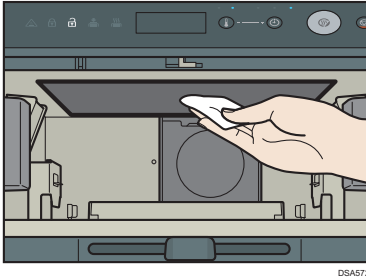









- We recommend cleaning the heater before using the machine (while the heater is cool).
- If you clean the heater while using the machine, clean it after the high temperature caution indicator () goes out and the heater cools down sufficiently.

■ Precautions about yellowing of the fabric

- If the fabric turns yellow after it is heated, you can prevent this discoloration by setting a lower temperature.
- The temperature can be changed by 5°C increments.
- Lower the temperature by 5°C and perform printing, and then confirm the yellowing disappears.





Setting Example

Depending on your environment, discoloration may occur or the ink may not be fixed properly. Before configure the settings, check the fixability of the fabric you use.

Fabric type	Mode	Temperature	Press time	Fixing time
T-shirt	Standard mode Professional mode	170°C (338°F)	 30sec	 3min
Tote bag (thick)		170°C (338°F)	 30sec	 3min
Tote bag (thin)		150°C (302°F)	 30sec	 3min
Sweatshirts		170°C (338°F)	 30sec	 3min

The example settings minimize discoloration caused by washing, although it is a little time consuming.

The surface of the heater and the fabric are in contact with each other during the fixing process, so regular cleaning of the surface of the heater is necessary.

Fabric type	Mode	Temperature	Press time	Fixing time
T-shirt	Professional 2 mode	180°C (356°F)	 30sec	 30sec   3min

Troubleshooting

★ Important

- Temperature and time settings will vary depending on the fabric used by the customer (T-shirt, tote bag, etc.). Before configure the settings, wash with the garment you use and check the fixability.

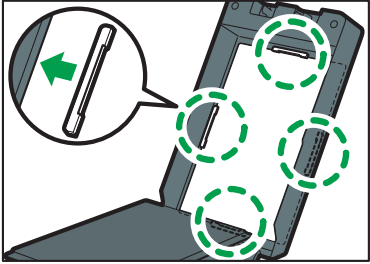
Problem	Cause	Solution
Ink does not fix properly.	Appropriate temperature is not set.	Change the temperature setting. When you set a custom temperature, see "Set Temperature and Time".
Ink does not fix properly.	Appropriate time is not set.	Change the time setting. "Medium" (3 minutes) (Default setting) ▶ "Long" (6 minutes) When you set a custom time, see "Set Temperature and Time".
Fabric color changes.	Appropriate temperature is not set.	Change the temperature setting. "High" (170 °C, 338°F) (Default setting) ▶ "Low" (150 °C, 302°F) When you set a custom temperature, see "Set Temperature and Time".
Fabric color changes.	Appropriate time is not set.	Change the time setting. "Medium" (3 minutes) (Default setting) ▶ "Short" (1 minute) When you set a custom time, see "Set Temperature and Time".
Fabric color changes.	The heater and the fabric might be in contact with each other during fixing processing.	Before setting the fabric, attach the spacers included in the tray on the four sides of the inside of the tray. It is possible to prevent the heater and the fabric from coming into contact during fixing processing. 

DSAS45

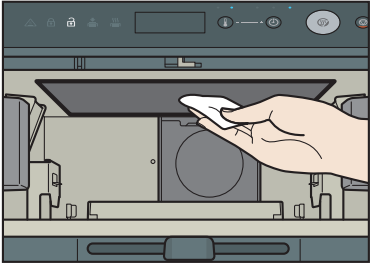
Problem	Cause	Solution
Fabric becomes dirty.	The heater or the surface of the table in the tray might be dirty.	After the high temperature caution indicator goes out and the heater cools down sufficiently, wipe off the dirt with a soft, dry or damp cloth.  DSA572
An error message appears on the display of the printer Ri 100. "Temp. alert Please wait..."	<ul style="list-style-type: none"> Using this machine continuously may make the tray hot. An abnormal temperature may be detected inside the printer Ri 100 as a high temperature tray is installed. 	Wait until "Ready" appears on the screen of the printer Ri 100.
An error message appears on the display of the printer Ri 100. "Cannot use High Temp." "Power Off On"	<ul style="list-style-type: none"> Using this machine continuously may make the tray hot. An abnormal temperature may be detected inside the printer Ri 100 as a high temperature tray is installed. 	Turn on the power to the printer Ri 100 again and wait until "Ready" appears on its screen.
The time/temperature indicator light shows "not ready" and the alarm rings.	The mode switching lever was operated before preheating was completed.	Do not operate the mode switching lever until after preheating is completed. Return the mode switching lever to the center after preheating is completed. Resume the preheating process.
After preheating is completed, the heater temperature display of the time/temperature indicator of this machine is lower than the set temperature, and the [Preheat] key is lit.	The heater auto-off function might have been applied. See "Precautions when using the machine".	Press the [Preheat] key to restart preheating.

If the control panel does not light up or the temperature of the time/temperature indicator on the control panel does not rise after the [Preheat] key is pressed to start preheating, this machine might be malfunctioning. Stop using it immediately and contact your dealer or service agent.

Note

- Before attaching the spacers, make sure that the tray is sufficiently cool. Before removing the spacers, make sure that the tray and spacers are sufficiently cool.
- If the fabric's color does not change or the fabric does not become dirty, remove the spacers and use just the tray.

Cleaning

To clean the exterior of the machine, wipe it with a soft, dry or damp cloth. If the dirt does not come off, wipe the machine first with a cloth moistened with a neutral detergent, then with a damp cloth, and finally with a dry cloth.

★ Important

- Do not use volatile chemicals like benzene or thinner, or insecticides on the machine. Using these chemicals could deform, crack, or change the color of the machine.
- When wiping the machine with a cloth moistened with detergent, be sure to wipe only the exterior.

Specifications

■ Power source

 **Region A** 220-240 V: 50/60 Hz

 **Region B** 120-127 V: 60 Hz

■ Power consumption

 **Region A** 980-1,160W

 **Region B** 1,240 W

■ External dimensions

(W × D × H) 419 × 675 × 235 mm (16.5 × 26.6 × 9.3 inches)

■ Weight

16.5 kg (approx. 36.4 lb.)

© 2017, 2018 Ricoh Co., Ltd.

EN (GB) EN (US) EN (AU)

J361-6705E